

# 'ATD28' Outdoor LED Display Systems:

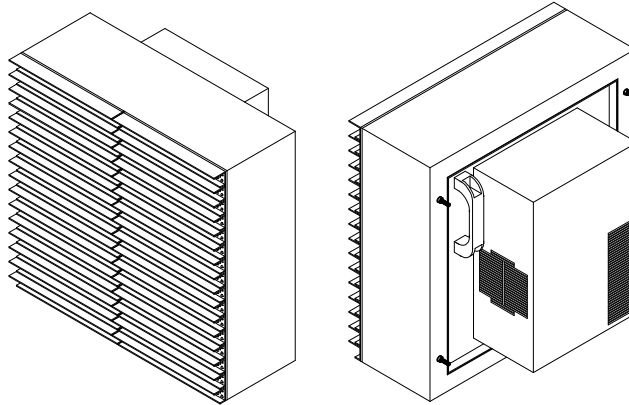

## 1 Introduction

Technographic Displays' outdoor display products combine proven design features with a number of unique innovations.

The latest outdoor display module in the Myriad range is the ATD28. The standard ATD28 display module measures 445mm x 445mm and comprises 256 full-colour high-brightness LED pixels (16 pixels x 16 pixels). The design of the ATD28 sub-assemblies is such that variations of this format are readily achievable in applications where the standard module is not ideally suited. ATD28 display modules can be configured in almost any arrangement to create a wide range of display types and sizes.

Three standard colour options are available: red, amber, and full-colour (red-green-blue). The full-colour option can display up to 16 million colours. Other colours and colour combinations may be made available on request.

A range of powerful display controllers designed and supported in-house is available to complement the excellent range of display modules. The controllers support static and moving text and animated graphics.

Applications range from simple electronic information boards to full-function sports scoreboards and giant full-colour advertising displays.

Technographic Displays can supply display products to system integrators, or we can provide turnkey solutions to end-users. In either case, we provide total commitment to backup and support.

**brilliant display technology**

## 2 ATD28 display modules

### 2.1 Design features

#### 2.1.1 Pixel configuration

ATD28 display modules are available with the following pixel configurations:

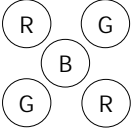
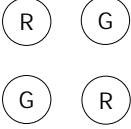
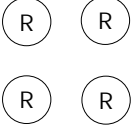
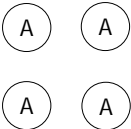
High-brightness full-colour pixel  (-F version)	
High-brightness red-green-amber pixel  (-T version)	
High-brightness red Pixel  (-R version)	
High-brightness amber pixel  (-A version)	

R = AlInGaP Red LED  
 A = AlInGaP Amber LED  
 G = InGaN Pure Green LED  
 B = InGaN Blue LED

#### 2.1.2 Viewing angle

Each of the pixel options is available with various viewing angles to suit different applications.

For example, a stadium scoreboard or building-mounted advertising display may require a wide viewing angle, whereas an information display mounted above a roadway may demand a higher brightness with a narrower viewing angle.

Standard ATD28 display modules employ elliptically-lensed LEDs with a total half-brightness horizontal viewing angle of 70° and a total half-brightness vertical viewing angle of 30°. Other viewing angles are available to special order.

### 2.1.3 Automatic brightness adjustment

At night, or in conditions of low ambient light, an ATD28 display will appear much too bright when set to full-brightness. For this reason, automatic display brightness adjustment is provided as a standard feature.

### 2.1.4 Mechanical details

The ATD28 display is fully modular for ease of installation and maintenance. The module size is 445mm x 445mm.

ATD28 modules are fabricated from marine-grade aluminium alloy with stainless steel fittings.

Each row of pixels incorporates a horizontal shade, which maximises the contrast of the display in bright, sunny conditions without compromising the horizontal field of view.

The modules are mounted by four M6 studs onto a sub-frame, on a pitch of 447.04mm. Each module weighs only 10kg (or 11kg with heat exchanger – see 2.1.11); thus the weight of the modules is only 50kg/m<sup>2</sup>.

The front surface of the display is completely sealed against all weather conditions. The rear panel of each module should be used in conjunction with an additional light-coloured rear panel to reflect heat when likely to be exposed to outside weather conditions.

Technographic Displays can provide complete display housings and structural supports if required.

### 2.1.5 Maintenance

No regular maintenance is required, and ATD28 display modules are designed and built for a very long service life.

In the unlikely event of a failure, ATD28 modules are designed to allow easy field replacement of a complete module. This enables field-maintenance to be accomplished rapidly by operational or maintenance staff unfamiliar with the product. Handles are provided on the rear of each module to aid lifting, and each module is light enough (11kg) to be manoeuvred easily by one person.

Any subsequent repair work can be carried out in controlled conditions by Technographic Displays or by other trained personnel. This approach to maintenance has been proven over the many years of operation of similar displays in harsh environments.

2.1.6 Data distribution

Data is distributed between ATD28 display modules via a fibre optic system. Advantages of this system are:

- Very high reliability.
- Zero electromagnetic radiation from inter-module cabling.
- Not susceptible to electromagnetic interference or EMP.
- Low cost.
- Suitable for all weather conditions.

2.1.7 Pixel-levelling memory for display modules

The standard DC4500 display controller incorporates a pixel-levelling memory which provides multiplying values in order to adjust the brightness of every pixel in the screen. In the ATD28-P, the brightness values are stored in memory on each display module and read by the display controller at power-up or when instructed to do so. In this way replacement display modules can be pre-levelled (in the factory) and also a display does not have to be re-levelled in the event of a replacement controller being fitted.

2.1.8 Send-back from screen modules

Data is fed from the DC4500-R display controller to the display modules and between the modules via fibre-optic links. By incorporating a send-back facility in each module and feeding the fibre-optic signal from the end of each fibre-optic chain back to the display controller, it is possible to monitor the status of the screen. A read-back board is fitted to the DC4500-R controller for this purpose.

Parameters which can be monitored include the following:

- Internal temperature of each module
- Power supply status ('power good') of each module
- Serial number of each module
- Number of hours run by each module
- Pixel-levelling memory

2.1.9 Extra Low Voltage operation

The ATD28-S display modules are mains-powered, whereas the ATD28-P modules are powered by a 48Vdc (SELV) supply.

In this case, a high-reliability 230Vac to 48Vdc rectifier is housed separately in the equipment enclosure. The rectifier system comprises n+1 parallel redundancy with hot-swappable rectifier modules for ultimate reliability. The advantages of this configuration are as follows:

- Simplified earthing requirements.
- Displays can be powered from RCD-protected source for safety.

- High efficiency (up to 90%) for minimum temperature rise inside module.
- Extra Low Voltage with soft-start enables safe hot swapping of modules.
- Very high reliability, dc-dc converters.
- Excellent immunity to external transients due to EMP, etc.

Features of the 230Vac to 48Vdc rectifiers are as follows:

- 91% efficiency including series output diode.
- Comprehensive alarm signals.
- -40°C to +64°C operation.
- Fan cooled.
- Hot-pluggable.

### 2.1.10 Power supply redundancy

Each ATD28-P module has a dual redundant (fault-tolerant) power supply. In the event that either power supply circuit should fail, the module will continue to work as normal, and the fault will be reported via the send-back mechanism.

Features of the power supply are as follows:

- Maximum load required by module: 120W.
- Output power capability 280W (fault-free).
- Output power capability: 140W (one circuit failed).
- Comprehensive input transient protection.
- Input soft-start circuit eliminating the requirement for phased start-up of display.
- Built-in EMC filtering.
- Dual optically-coupled outputs for the control of dc cooling fans.
- PSU status output.

### 2.1.11 Heat exchangers

A light-weight air-to-air heat exchanger has been designed specifically for use in the ATD28-P display module. This device enables adequate cooling of the electronics within the display modules without the flow of potentially dirty air, and will dramatically extend the lifetime of display modules situated in polluted environments including roadside locations.

2.1.12 Summary: Semi-professional and Professional series ATD28 display modules

The following table provides a convenient comparison between the 'semi-professional' and 'professional' series ATD28 modules:

	Semi-professional module ATD28-S	Professional module ATD28-P
Power input	<b>230Vac (TN-S)</b>	<b>48Vdc (FELV)</b>
Internal power supply unit	<b>Single mains switched mode PSU</b>	<b>Dual redundant dc-dc power converters. If one converter should fail, then the display module will continue to operate normally, and the user will be alerted to the failure.</b>
Data input	<b>Fibre optic</b>	<b>Fibre optic</b>
Data output	<b>Fibre optic, with packets modified for remote diagnostics.</b>	<b>Fibre optic, with packets modified for remote diagnostics.</b>
Pixel-levelling possible	<b>Yes</b>	<b>Yes</b>
On-board pixel-levelling memory	<b>Yes</b>	<b>Yes</b>
Temperature control	<b>Air-to-air heat exchanger for increased lifetime and reliability in damp or polluted environments. Dual fan system with separate thermostatic control.</b>	<b>Air-to-air heat exchanger for increased lifetime and reliability in damp or polluted environments. Dual fan system with separate thermostatic control.</b>
Display controller required	<b>DC1000 or DC4500</b>	<b>DC1000 or DC4500</b>
Module weight	<b>10kg</b>	<b>11kg</b>

### 3 Display controllers

A range of display controllers designed and built by Technographic Displays is available to control the ATD28 display modules. Technographic Displays will be pleased to advise on the most appropriate display controller for each application. Systems incorporating more than one display can comprise different model display controllers for different displays, depending on display size and requirements.

Systems can also incorporate other types of display such as CRT monitors, full-colour plasma panels, LCD information displays, etc.

The DC1000 and DC4500 LED display controllers can also be configured to control DCM15, DCM10 and DCM7 full-colour video display modules manufactured by Invision Microsystems.

Features of the DC1000 and DC4500 display controllers are as follows:

- 24-bit full-colour operation (16 million colours).
- Animated text and graphics.
- Pixel levelling (DC4500 only) to enable replaced pixels to be matched in brightness to the remainder of the display.
- Radio remote control interface (option on DC4500) to enable manual pixel levelling to be performed from the most convenient location.
- Fibre-optic output.
- Fibre-optic read-back for pixel levelling and remote diagnostics.

## 4 Control systems

Technographic Displays' systems are supplied with a powerful, easy-to-use PC-based interface, which may control one display or a network of two or more displays.

Messages may comprise static and moving text and pre-prepared animated graphics. The user-interface enables the entry of text messages and the selection of animations. Animated graphics may be pre-prepared by Technographic Displays, or, given suitable third-party software, by the user.

Messages are displayed in a cycle, and may be scheduled to appear at certain times of the day and / or days of the week. An integrated weekly timetable-based system is also available for certain applications. Sports scoreboard software can be supplied, and may be tailored for individual sports or a range of sports.

The user interface has been designed and written in-house and can therefore be customised by Technographic Displays if required.

## 5 Turnkey solutions

Technographic Displays can provide a turnkey solution to any large area display requirement.

The in-house design team has many years' experience in designing and installing such systems, including information and advertising systems at many major sites in the UK. Where appropriate, specialist sub-contractors are employed to provide installation support services, such as civil engineering, structural steelwork, power and data cabling.

No matter how large or small the installation, Technographic Displays has the knowledge and experience to cope, whilst providing value for money and very high quality solutions.